

# SU3000

DESCRIPTIVE SPECIFICATIONS



The Supervisor 3000 optical turnstile has a slim profile and stylish, architectural design that enhances any access control installation. The SU3000 has motorized barrier arms that quickly move down and into the cabinet to provide high throughput in both passage directions.

## COMMON APPLICATIONS

- Employee and Visitor Access Control
- Time & Attendance Integration
- Loss Prevention

## TYPICAL INSTALLATION SITES

- Government Facilities
- Corporate Lobbies
- Entertainment Venues

## FUNCTION

The Supervisor 3000 provides bi-directional access control and other operational and passage modes (described below). In access control mode, upon receipt of a valid card signal from an access control system, the motorized barrier arms of the turnstile quickly retract down and into the cabinet, and the integrated sensors allow a single user to pass through the turnstile in the requested direction. If an unauthorized user attempts to tailgate on the entry, the unit will recognize the illegal passage, a violation alarm (with user configurable sounds) will sound, and red notification lights will flash.

The SU3000 utilizes tandem motorized arms and integrated optical sensors to control access. The optical sensors detect patrons, determine the direction of patron movement, and (in conjunction with the facility access system) detect unauthorized users. In addition to detecting “piggybacking” or “tailgating” on allowed entries, the SU3000’s sensors prevent the barrier arms from closing on users. If the barrier arms do encounter an obstruction on either opening or closing, the SU3000’s software detects the obstruction and takes corrective action, precisely controlling the motors to minimize impact.

While access control throughput will depend on the access control system and readers used, the SU3000 supports extremely rapid throughput. It will “stack” valid scans and process patrons as fast as they can walk through the turnstile.

Configurable features of the SU3000 are set in the field using an application (included) called LaneConfig. This application allows core configurable features – such as alarm sounds, motor settings, optical settings, detection settings, tailgating, safety sensor settings, barrier speed, alarm timer settings, etc. – to be changed and uploaded over a TCP/IP network at the installation site. Turnstiles can also be configured by loading LaneConfig on a laptop and plugging directly into an Ethernet port in the turnstile. More information about LaneConfig and the many configurable features of the SU3000 are described further in this document.

Embedded IP-based communication and configuration functionality is included in all SU3000 optical turnstiles, making it possible to adjust core turnstile settings via a local and/or remote TCP/IP network session. LaneConfig allows authorized security personnel and technicians to load software updates and set individual turnstile parameters including:

- Alarm sounds and alarm timer settings
- Optical settings for detection of lane passage, tailgating
- Motor settings, barrier breakaway, sensitivity and speed settings

More information about LaneConfig and various SU3000 communication and configuration options are described elsewhere in this document.

The embedded IP-based functionality of SU3000 optical turnstiles also allows a number of other methods of advanced configuration/control using a secure web page that can be viewed in a standard Web browser. This includes setup of IP addresses, network adapter and other settings. Additional remote desktop tools allow troubleshooting and diagnostics without an actual physical presence at the turnstile.

## AVAILABLE CONFIGURATIONS

### SU3000 & SU3000E

The SU3000 consists of a pair of end cabinets with barrier arms that create a single 28" (711mm) wide passageway. The SU3000E is an extension center cabinet, with the same dimensions as an end cabinet, used to create additional turnstile passage lanes with the addition of a single cabinet. For example, one SU3000 and one SU3000E would be used to create two turnstile lanes. Additional extension center cabinets are used to create additional turnstile lanes; e.g., one SU3000 and two SU3000E's create three turnstile lanes. An unlimited number of center cabinets can be added.

### SU3000-A & SU3000E-A

The SU3000-A consists of a pair of end cabinets with barrier arms that create a single 36" (914mm) wide passageway. The SU3000E-A is an extension center cabinet with barrier arms on both sides of the cabinet, to allow an additional 36" turnstile passage lane to be created with the addition of a single cabinet as described in the section above. An unlimited number of center cabinets can be added.

## AVAILABLE FINISHES

### STAINLESS STEEL, POWDER COATED & PLATED

External cabinet materials are fabricated from #304 stainless steel polished to a #4 satin finish. Powder coated and plated cabinets are available (see Options).

## MATERIALS

### CABINET

Cabinets are fabricated from #304 stainless steel. Powder coated and plated cabinets are available (see Options). The cabinet base is fabricated from formed and welded carbon steel which is powder coated black.

### INTERNAL FRAME

A powder coated steel internal frame houses electronics, motors and other internal components.

### CABINET LIDS

Cabinet lids are fabricated from 100% acrylic resin (Color: Starry Night Black). Alternate acrylic resin colors and alternate materials can be provided (see Options).

### BARRIER ARMS

Barrier arms are fabricated from 1.75" (44mm) diameter aluminum tubing with a clear anodized finish.

## CONTROL, OPERATIONAL MODES & FUNCTIONALITY

### CONTROL MECHANISMS

The precise movement of the SU3000's motorized barrier arms is accomplished through DC brushless motors working in conjunction with position encoders and motor controllers. A main turnstile controller runs the operational application and interfaces to the motor controllers and optics over an internal high speed serial network. The turnstile controller also interfaces to outside configuration and administrative applications, LaneConfig and / or GateKeeper, via TCP/IP – see Available Related Applications.

### PASSAGE MODES

The following user-configurable passage modes are available:

**Controlled Passage** - *Note: Controlled Passage is provided in three operating modes: normally closed; normally open; or barrier disabled (see below). Normally closed operating mode is described here.* The arms are up, securing the turnstile. Upon receipt of an authorization signal from an access control system the arms move down to the open position, allowing a single passage in the authorized direction. The arms return to the closed position after the user has passed through the turnstile or the time frame allowed for an entry to occur has expired. Controlled Passage mode can be implemented either in a single direction or bi-directionally.

**Free Passage** - An authorization signal is not required for a user to pass through the lane. Free passage works in both Normally Closed mode (arms up until pedestrian enters the lane) or Normally Open mode (arms remain down at all times). Free Passage mode can be implemented either in a single direction or bi-directionally.

**No Passage (Lane Closed)** - No passage is allowed. The arms are up, securing the turnstile. Valid electronic credentials are ignored. No Passage mode can be implemented either in a single direction or bi-directionally.

### OPERATING MODES

The SU3000 offers the following user-configurable operational modes:

**Normally Closed** - See Controlled Passage mode description above.

**Normally Open** - The arms are down, providing a barrier-free passageway. The arms will not raise and secure the turnstile unless tailgating or unauthorized passage is attempted. Normally Open mode should be used only in select applications. Contact Alvarado for recommendations.

**Barrier Disabled** - The arms remain down at all times allowing the SU3000 to function as an optical (barrier free) access control turnstile.

### USER STATUS DISPLAY

An illuminated status icon display, visible to users, is flush mounted within the cabinet lid and is configured to function in the following manner:

**Yellow Icon** - An illuminated yellow card means the turnstile is ready for card presentation.



**Green Arrow Icon** - An illuminated green arrow indicates passage is allowed in the direction of the arrow and / or valid credentials have been presented. A flashing green arrow indicates the turnstile is in Free Passage mode in the direction of the arrow.



**Red Stop Icon** - An illuminated red X indicates passage is prohibited in the direction of the arrow. A flashing red X indicates the turnstile has an alarm condition and / or invalid credentials have been presented.



### OPEN / CLOSED STATUS LIGHTS

An opaque end piece is mounted to the upper end “leg” on each side of the turnstile, diffusing green and red signal lights. The lights function similar to toll booth lights, and perform in the following manner:

**Green** - An illuminated green bar indicates the turnstile is open for use. The bar remains green when a valid card input is received.



**Red** - An illuminated red bar indicates the turnstile is closed for use. The barrier arms will not open in the direction of travel unless the direction is “exit” and fire alarm or life safety input is received.



**Red Flashing** - A flashing red bar indicates the turnstile has an alarm condition. The duration of the alarm condition and flashing is user definable through LaneConfig software.

### FUNCTIONALITY - USER CUSTOMIZABLE FEATURES & AVAILABLE TOOLS

In addition to the available passage and operating modes, the SU3000 has a number of additional user customizable features. These features allow turnstiles to be “tuned” to the operational requirements of an application and allow users to associate individual audio sounds with operational states and alarm conditions. SU3000 turnstiles also come with tools to assist service personnel with setup, diagnostics and troubleshooting.

Customizable features and custom sounds are downloaded to turnstiles over a TCP/IP network using the included LaneConfig application. The product ships with standard sounds. Users may create and install their own audio sounds in the form of .wav files.



# DESCRIPTIVE SPECIFICATIONS

## OPTICAL TURNSTILES

# SU3000

Prior to shipping, turnstiles are configured with settings that are appropriate for most facilities and default sound files are loaded. A summary of configurable features, and setup and diagnostic tools, is listed below.

Operational Tuning Adjustments	Description
Barrier Breakaway	Controls barrier arm breakaway force if arms are manually pushed down
Barrier Impact	Controls barrier arm operation if the arms encounter an object during operational cycle
Access Timeout	Valid credential presented but user does not pass through turnstile; controls time before arms close and turnstile resets
Object	Controls object detection size
Tailgating	Controls tailgating sensitivity
Unauthorized Entry	Controls number of entry sensors user can block before triggering alarm
Blocked Sensor	Controls time before alarm is generated if sensors are blocked

Operational Sounds / Alarms*	Description	Configurable Sounds
Access Granted	Good card	√
Access Denied	Bad card	√
Unauthorized Presence	User enters turnstile without presenting card	√
Tailgating / Unauthorized Passage	Tailgating / unauthorized passage detected	√
Blocked Sensor	Sensors not cleared	√
Blocked Sensor (arms closed)	Arms are not closing due to unsafe condition	√
Blocked Sensor (arms open)	Arms are not opening due to unsafe condition	√
Barrier Breakaway (universal sound)	Arms have been forced open	√
Barrier Impact (universal sound)	Arms encountered an object when moving	√

\* Unless noted, sounds are configurable for both entry and exit direction.

Setup / Diagnostic Tools	Description	Configurable Sounds
Barrier Position (Home)	Barrier arm home position setting	N/A
Barrier Position (Open)	Barrier arm opening position setting	N/A
Startup	Appropriate startup engaged	√
Barrier Lingers	Arms have stayed open past the allotted time to close	√
Debug	General debug application for troubleshooting	N/A
Optic Debug	Debug application for optics	N/A
Motor I/O Debug	Debug application for motor communication	N/A
Electromechanical Brake	Controls whether brake is used or not	N/A
Emergency Override Direction	Allows installer to set emergency override direction	N/A

### ALARM CONDITIONS

In the event of an alarm condition, the designated alarm sound is played (see chart on previous page) and both the status icon display and open / closed status lights will illuminate red for the defined time. An I/O output is also provided for most alarm conditions - see Turnstile Interface To Access Control System.

### BARRIER BREAKAWAY

All SU3000 turnstiles utilize motor force and if enabled, an electromechanical brake to provide adjustable resistance against a user pushing the barrier arms open. The force it takes to push the arms open is an adjustable setting, up to the product maximum. Approximate maximum holding force measurements are available from Alvarado. When the set or maximum holding force is reached, the arms "break away" and can be moved manually. The arms automatically reset to the home (closed) position when the user exits the lane.

### BARRIER CYCLE TIME

This is an adjustable feature. Factory set opening, and recommended, speed is approximately 500ms.

### BARRIER IMPACT

In the event that the barrier arms encounter resistance while opening or closing, the arms will stop moving, an alarm will sound and the status icon display and open / closed status lights will illuminate red to indicate an alarm condition. At this point, the arms can be moved manually. The arms will automatically reset to the closed position once the obstruction is cleared from the lane. The barrier impact setting is adjustable.

### EMERGENCY OVERRIDE / FIRE ALARM

Activation to open the arms in conjunction with a fire alarm or other life safety system is achieved by supplying a sustained dry contact to the SU3000. During emergencies the SU3000 arms will open in the exit direction and remain open. Status lights and alarm notifications will turn off.

### POWER FAILURE

In the event of a loss of power to the unit, the arms of the SU3000 can be freely moved in either direction. When pushed to the open position the arms will remain open.

## CARD READERS

### SPACE FOR INTERNAL INSTALLATION OF CARD READERS

Internal space is available for mounting of slim style proximity card readers. The internal space available is 1.0" H x 1.9" W x 6.5" D (25mm x 48mm x 165mm). Use of larger readers is accomplished through custom solutions (see Options).

### TURNSTILE INTERFACE TO ACCESS CONTROL SYSTEM

There are two types of interfaces to allow an access control system to operate with the SU3000:

**DRY CONTACT** - Single passage activation, and other functionality, is achieved by supplying an isolated, voltage free, momentary dry contact at the appropriate location on the I/O control board. Various outputs are also available to provide information on turnstile operational status and activity. A description of available input and output signals is provided below.

Input Signal	Entry / Exit
Direction Closed	√
Good Card (Activation)	√
Bad Card	√
Passage - Free Pass Mode	√
Single Entry Override	√
Life Safety Input	√

Output Signal	Entry / Exit
Authorized Passage	√
Unauthorized Passage	√
Unauthorized Presence	√
Sensor Blocked	√
Lingering Barrier	√

**GATECONNECT** - For large projects a TCP/IP interface is available through use of Alvarado's optional GateConnect application. This application allows a third party access system to control turnstile operation similar to the dry contact method, through the use of TCP/IP commands and responses. There is an additional charge for GateConnect and implementation requires a one-time programming effort on the part of the access system provider. Contact Alvarado for pre-evaluation of project requirements.

### AVAILABLE RELATED APPLICATIONS

There are two additional applications that are available with the SU3000.

**LANECONFIG** - LaneConfig is a desktop application that comes standard with all SU3000's. The application allows configurable features of the SU3000 and updated software to be installed over a network. Use of LaneConfig in a networked setting eliminates the need to physically plug into individual turnstiles to change turnstile configurations or update software. LaneConfig is installed on a PC that is networked to installed SU3000 units and communicates to turnstiles via TCP/IP.

In installations where SU3000 turnstiles are not networked, LaneConfig is loaded on a laptop which is temporarily plugged into the Ethernet port of individual turnstiles when turnstile configurations are changed or software is updated.

**GATEKEEPER** - GateKeeper is an optional desktop application that allows all Alvarado optical turnstiles installed at a site to be monitored and controlled from a single PC. GateKeeper allows control of virtually all day-to-day operating functions, including designating a turnstile as entry or exit, opening or closing a turnstile, and allowing single passage overrides for guests or personnel that have forgotten their access card. The application also includes various other functions; these include an emergency "open all turnstiles" capability that is in addition to the emergency override / fire alarm capabilities described earlier in this document. The application has tiered login levels with three levels of security (User, Supervisor and Administrator). The higher permission levels enable various additional features and settings.



GateKeeper has an intuitive graphic interface that gives desk attendants a current “status” of all installed turnstiles. In addition, when alarm conditions occur, the application provides both visual and audio notification of what happened. All actions (such as passage overrides) and turnstile alarms are logged. Logs may be printed or saved for recordkeeping or diagnostic purposes.

GateKeeper also includes a built in Event Scheduler. This extremely useful tool allows day-to-day operational changes that are often implemented at sites to be scheduled and automatically implemented without the need for a guard or attendant to “remember” to change settings. Event Scheduler allows operation templates to be saved and then automatically implemented at user defined times. Examples include changing the entry status of turnstiles (entry, exit, bi-directional control or free passage) at set times of the day. Similarly, a facility may want barriers activated or disabled at select times and / or only specific lanes operational on weekends and holidays. This flexibility allows turnstiles to be used more efficiently, can decrease the number of turnstiles that may be needed, and allows Alvarado’s optical turnstiles to seamlessly integrate into a customer’s operational requirements.

A single license of GateKeeper allows users to control all turnstiles installed at a single licensed site.

## OPTIONS

### ALTERNATE LID COLORS AND MATERIALS

Cabinet lids may be ordered in alternate colors and materials.

### ALTERNATE POWER SUPPLY

A 220-240 VAC, 50 Hz power supply and appropriately rated key switch are utilized.

### BASEPLATE

A baseplate for either single turnstile or multi-turnstile configurations is available. The baseplate is powder coated black with a black non-slip coating in the passageway area. The baseplate includes enclosed cable runs and eliminates the need for trenching or stubbing up conduit from floor.

### CARD READERS / PHYSICAL ACCESS DEVICES

Due to the slim architectural profile of the SU3000, generally only mullion sized readers can be housed inside the cabinet. Custom fabricated solutions, including pedestals, are used to house alternative readers. When requesting use of readers other than mullion size, provide the manufacturer and model number to Alvarado for evaluation. Custom reader integration generally requires providing a sample of the actual reader to be used to Alvarado for design purposes.

### CUSTOM CABINETS

External cabinet materials may be powder coated in a variety of colors. Cabinet materials can also be plated in a variety of finishes.

### BREAKAWAY ARMS

The SU3000 arms can be broken away horizontally in the direction of travel.

### LONGER INTERCONNECT CABLES

Longer interconnect cables are available to accommodate installations where standard conduit runs are unavailable. The standard interconnect cable length is 13’ (396cm). Custom cables are available in 20’ (610cm) or 40’ (1220cm) lengths.

### TCP/IP (GATECONNECT)

See the description under Available Related Applications.

### TCP/IP (GATEKEEPER)

GateKeeper communicates with SU3000 turnstiles over a wired TCP/IP network. The program runs on current Windows operating systems. Wireless communication is available. See the full description under Available Related Applications or online at <http://www.alvaradomfg.com/gateKeeper.htm>.

### TURNSTILE KEY CONTROLS

Two 3-position key switches are installed on the turnstile to control passage modes for each direction of travel. Turning the key to one of three positions overrides current settings and places the turnstile in Controlled Passage, Free Passage or No Passage modes.

## CONDUIT REQUIREMENTS

### PRIMARY POWER SOURCE CONDUIT

.75" (19mm) power conduit for primary power must be run to each master controller cabinet.

Note: The product standard is 110-120VAC (use of 220-240VAC is an option).

### LOW-VOLTAGE & INTERCABINET COMMUNICATION CONDUIT

1.5" (38mm) conduit must be run to allow passage of the interconnect cable between cabinet sets. 13' interconnect cables are included. 20' and 40' interconnect cables are available options.

### ACCESS CONTROL SYSTEM & READER CONDUIT

The SU3000 has space for the acceptance of a .75" conduit for access control and reader cabling. Alvarado does not provide cables for access control systems.

### TCP/IP CONDUIT

Use of TCP/IP communication with LaneConfig, GateKeeper or GateConnect requires the running of an ethernet cable to each master controller cabinet. Do not run cable in the same conduit as AC Power. Wireless communication is available.

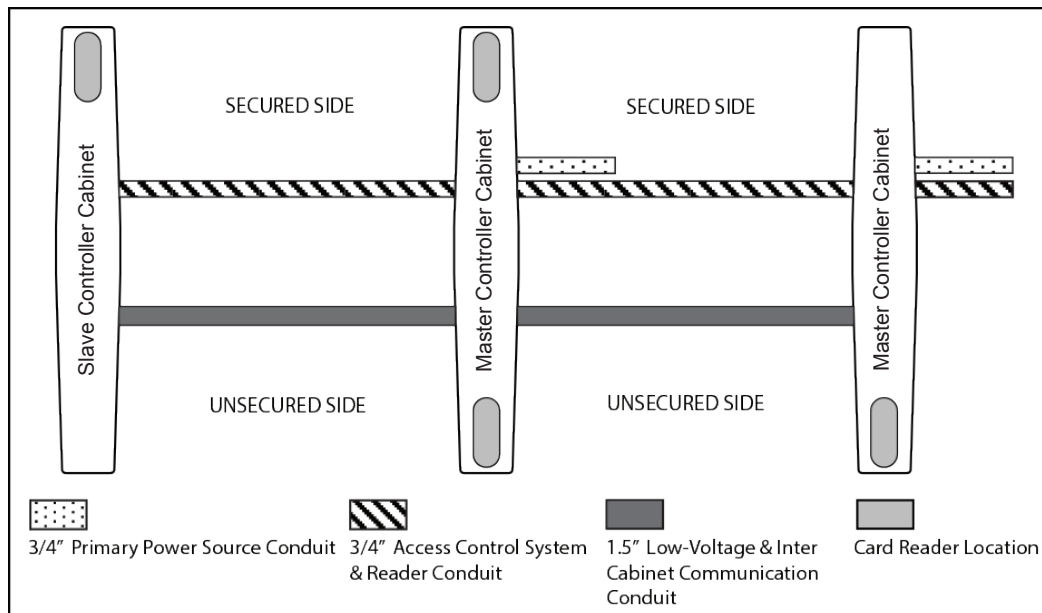

### SHIPPING & SITE PREPARATION

#### SHIPPING

SU3000 cabinets are shipped fully assembled for easy installation. Each cabinet includes mounting hardware (anchors, bolts, washers, etc.) to mount the unit to a standard, level concrete floor.

#### SITE PREPARATION

Turnstiles must be installed on a firm foundation in a manner that allows the required power and access control cabling to be pulled into the turnstile cabinet. The recommended slab platform should be a minimum of 4" (102mm) deep, level concrete. Installation should be performed by a skilled installer following Alvarado's instructions. Detailed drawings and installation manuals are available online.

### TECHNICAL DIMENSIONS

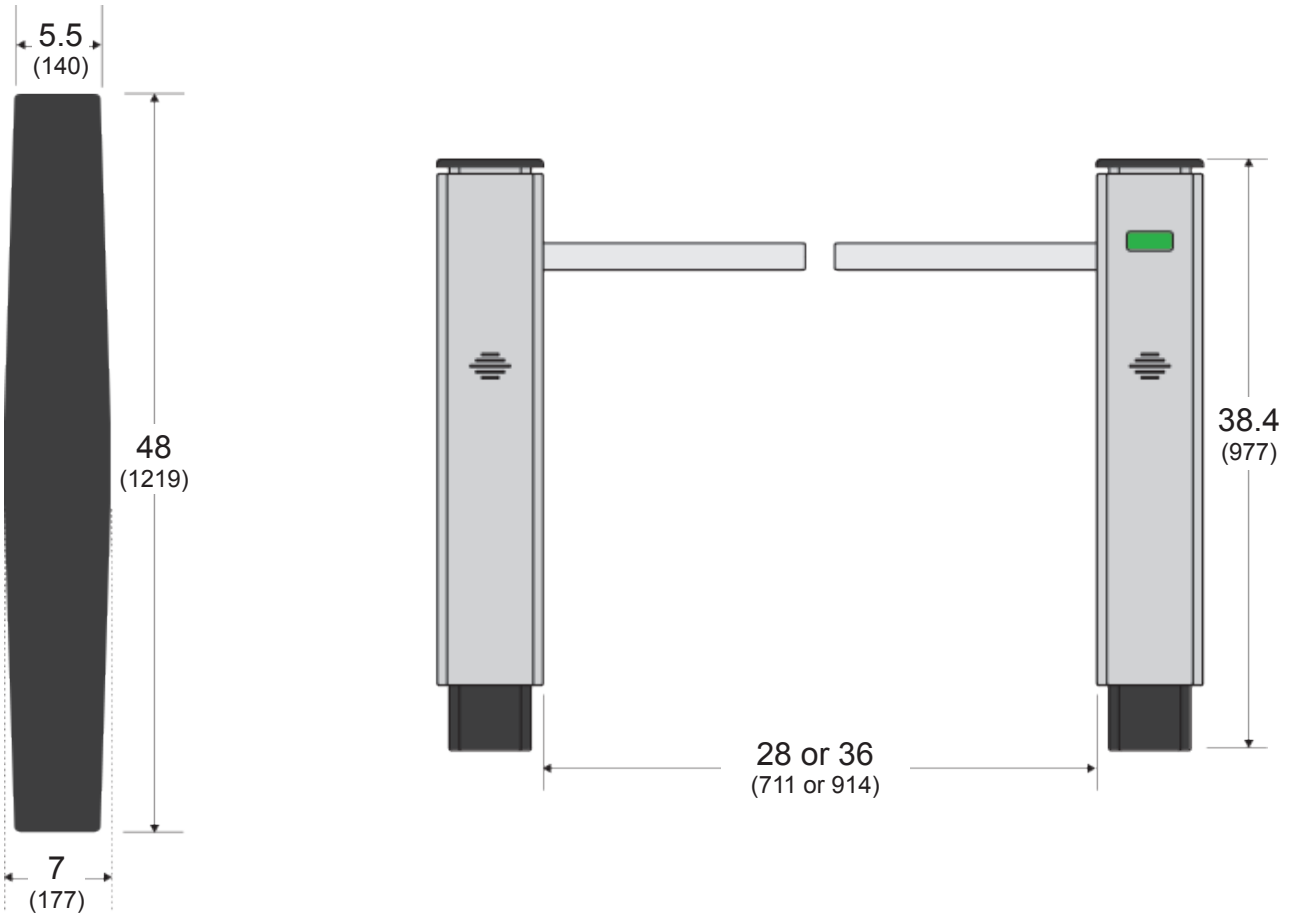

Same width for  
28" & 36" lanes

Dimensions shown in inches (mm). All measurements are approximate.

THROUGHPUT RATES			
CARD READER TYPE*	USERS PER MINUTE**		
PROXIMITY	40		
MAGNETIC STRIPE	25		
MAGNETIC STRIPE WITH NUMERIC KEYPAD	20		
*Access control system response is assumed to be instantaneous			
**Approximate. Rates may increase with user familiarity.			
ELECTRICAL			
	DESCRIPTION		
TRANSFORMER	110-120VAC, 60 Hz. or 220-240VAC, 50 Hz. (optional)		
POWER REQUIREMENTS	Maximum power consumption is 300W per lane with all options installed.		
OPERATIONAL VOLTAGE	Primary power is stepped down and rectified for low voltage 24 VDC, 12 VDC, and 5 VDC operation.		
ON/OFF KEY SWITCH	An on/off key switch is located on each master cabinet.		
FUSE PROTECTION	A 2.5 amp fuse (slo-blo) is installed in each master cabinet.		
SURGE PROTECTION	Alvarado suggests use of surge protection equipment in connection with the installation to protect electronics.		
DRIVE MOTOR	24V BLDC		
WEIGHT, DIMENSIONS, ENVIRONMENT			
	STANDARD	METRIC	
PRODUCT WEIGHT*	370 lbs.	168 kg	*Weight for a standard 28" lane (two cabinets)
SHIPPING WEIGHT**	660 lbs.	299 kg	**Includes weight of shipping crate(s)
HEIGHT	38.4"	977mm	
WIDTH	7"	177mm	
DEPTH	48"	1219mm	
OPERATING TEMPERATURE	50° to 90° F	10 to 32° C	
STORAGE TEMPERATURE	32° to 104° F	0 to 40° C	
RELATIVE HUMIDITY	15-85% (non condensing)	--	

## WARRANTY

For a period of 18 months from the date of purchase, Alvarado will replace or repair, at Alvarado's option, any products or parts which are defective in materials or workmanship, provided recommended installation and maintenance procedures are followed. This warranty is void if damage is due to improper installation, maintenance or use. This warranty is limited to parts only, and does not cover labor or shipping charges incurred in connection with the removal or replacement of warranted products or parts.

This warranty is expressly made in lieu of any and all other warranties, expressed or implied, including, but not limited to implied warranties of merchantability and fitness for a particular purpose. Alvarado shall not be liable for any loss or damage, directly or indirectly, arising from the use of purchased products. In no event shall Alvarado be liable to buyer for consequential damages, special damages, incidental damages, loss of use, business interruption, loss of profits, or damages of any kind arising out of the use or inability to use a purchased product. In no event shall Alvarado be liable for damages which exceed the purchase price of a covered product.